

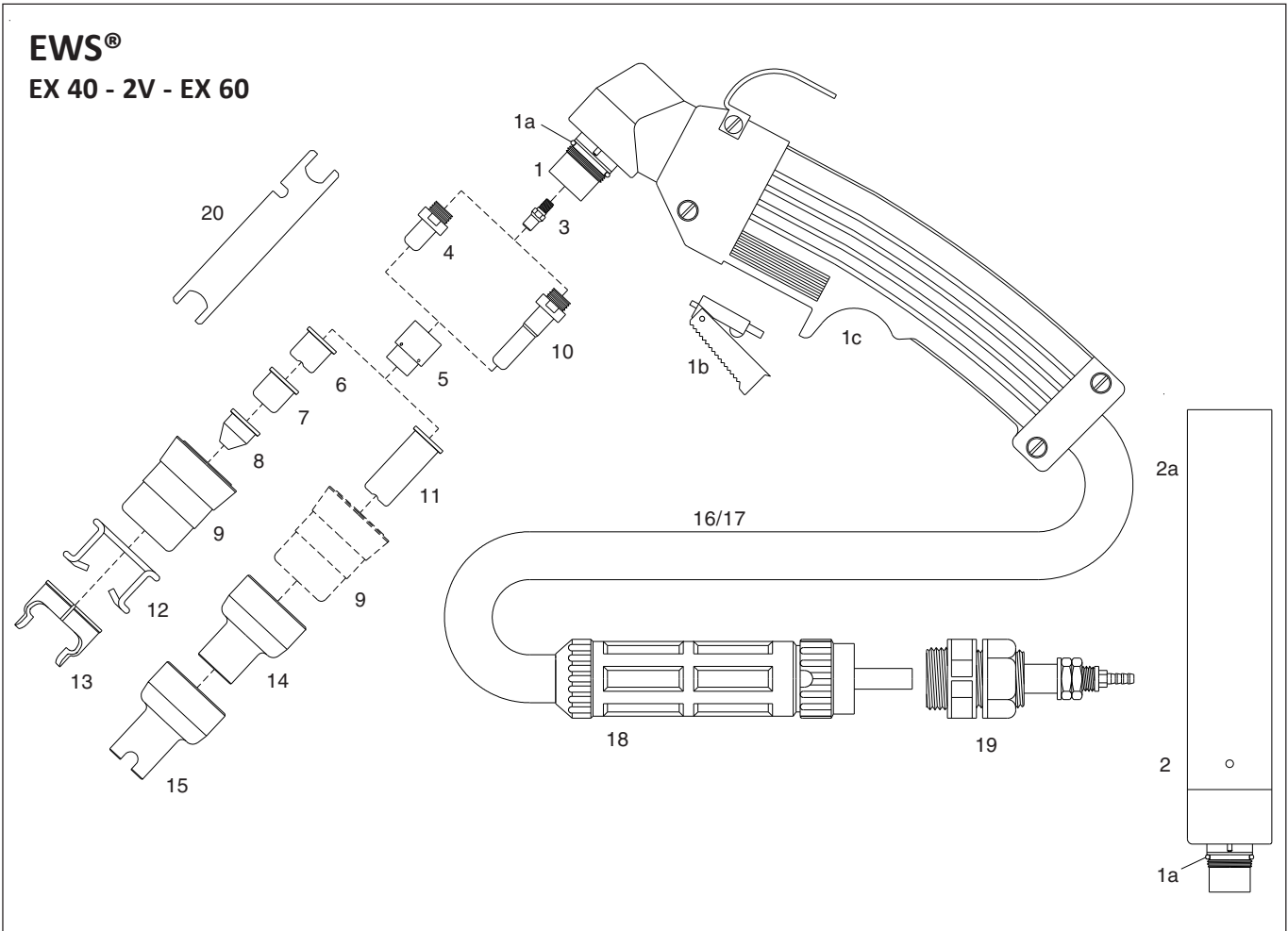

Replacement parts suitable for:



No.	Ref.	Code	Description	No.	Ref.	Code	Description
	W0400030	03072	Hand torch, 6m, central connector	8	W0300151	51098	Pipe saddle tip \varnothing 1.0
		03172	Hand torch, 12m, central connector		W0300152	51098.12	Pipe saddle tip \varnothing 1.2
	W0400046	03472	Machine torch, 6m, central connector	9	W0300109	60321	Retaining cap
	W0400033	03572	Machine torch, 12m, central connector	10	W0300110	52553	Extended electrode
1	W0300100	03270	Hand torch head	11	W0300236	51102.09	Extended tip \varnothing 0.9 35A
1a	W0300101	01000.60	O-Ring		W0300111	51095/L	Extended tip Long Life \varnothing 1.0 50A
1b	W0300103	07301.20	Switch		W0300237	51102/S	Extended tip Long Life \varnothing 1.1 60A
1c	W0300102	07301	Handgrip with switch		W0300112	51096/L	Extended tip Long Life \varnothing 1.2 70A
2	W0300148	03370	Machine torch head	12	W0300113	51901	Spacer spring
2a	W0300144	03310	Machine handle	13	W0300114	60363	Double pointed spacer
3	W0300104	01070.42	Diffuser	14	W0300238	51970	Shield cap hand for 51102.09 & 51095/L
4	W0300105	52551	Electrode	15	W0300239	51971	Spacer contact cutting for 51102/S & 51096/L
5	W0300106	60001	Swirl ring	16	W0300242	03241	Cable, 6m, 1/8", Hand torch
6	W0300155	51100.09	Tip \varnothing 0.9 35A		W0300243	03251	Cable, 12m, 1/8", Hand torch
	W0300107	51095	Tip Long Life \varnothing 1.0 50A	17		03321	Cable, 6m, 1/8", Machine torch
	W0300192	51100/S	Tip Long Life \varnothing 1.1 60A			03331	Cable, 12m, 1/8", Machine torch
	W0300108	51096	Tip Long Life \varnothing 1.2 70A	18	W0300117	04260-EWS	Central connector torch side
	W0300193	51100.12	Tip \varnothing 1.2 70A	19	W0300118	04265-EWS	Central connector machine side
7	W0300149	51099	Flat tip \varnothing 0.9	20	W0300119	60368	Wrench for electrode
	W0300150	51099.12	Flat tip \varnothing 1.2				

 **Notes**

EWS®
EX 100
EX 100 M
EX 100 M-3V

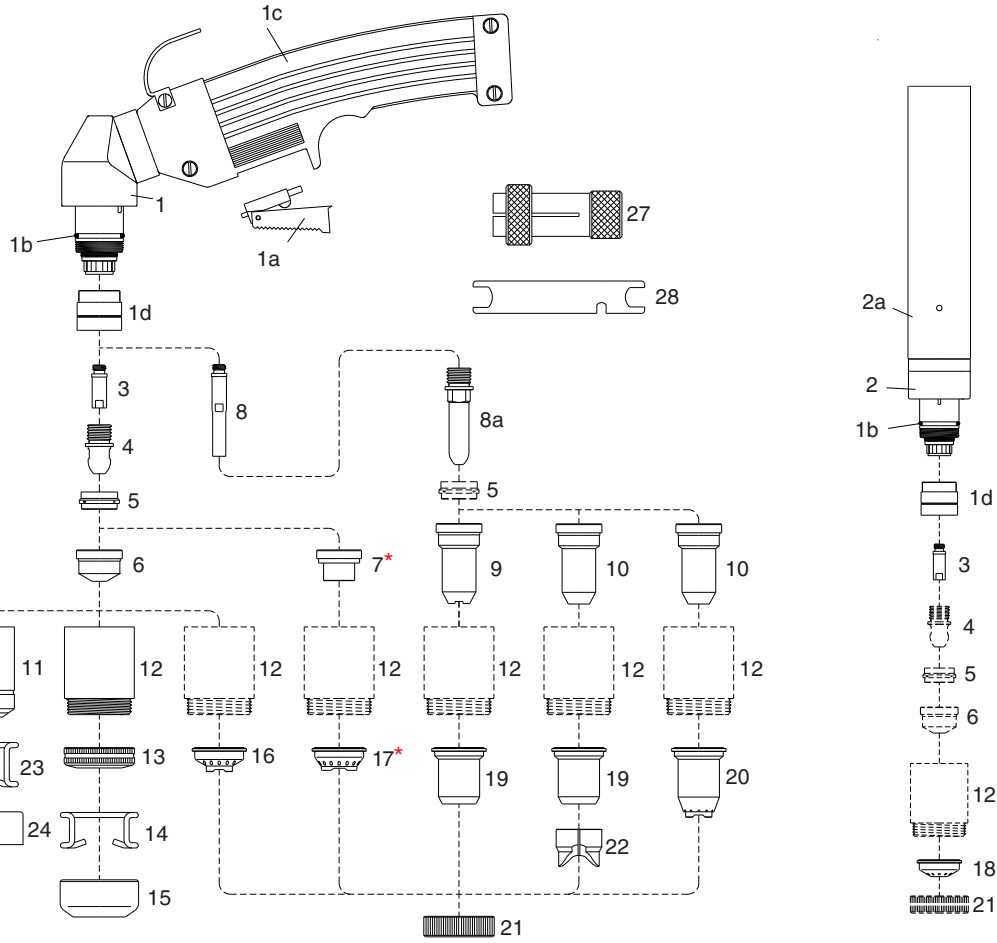

* while stocks last

No.	Ref.	Code	Description	No.	Ref.	Code	Description	
		W0400052	01252	Hand torch 6m central connection				
		W0400037	01352	Hand torch 12m central connection				
		W0400034	01452	Machine torch 6m central connection				
		W0400035	01552	Machine torch 12m central connection				
1	W0300263	01200	Hand torch head	11	W0300129	60328	Retaining cap	
1a	W0300103	07301.20	Switch	12	W0300138	60348	Contact retaining cap	
1b	W0300121	02000.60	O - Ring			60348/V	Contact retaining cap, Max.life	
1c	W0300102	07301	Handgrip complete with switch	13	W0300244	51952	Spring holder protection nut	
1d		60085	Front insulator	14	W0300245	51911	Spacer spring for code 51952	
2	W0300143	01400	Machine torch head	15		51953	Gouging spacer	
2a	W0300144	03310	Machine handle	16	W0300180	51950	Spacer for contact cutting, hand	
3	W0300122	06004	Diffusor	17*		51930	Spacer for contact cutting, hand	
4	W0300123	52540	Electrode	18	W0300181	51951	Shield cup, machine	
5	W0300124	60020	Swirl ring	19	W0300182	51957	Shield cup, hand (max. 50A)	
6		51140/S	Tip long life ø 1.1	20	W0300183	51958	Spacer for contact cutting, hand	
		W0300174	51141/S	Tip long life ø 1.35	21	W0300184	51959	Locking nut
		W0300175	51142/S	Tip long life ø 1.6	22		51974	Spacer for extended tips High Amp.
		W0300128	51144.24	Gouging tip ø 2.4	23	W0300130	51910	Spacer spring
7*	W0300135	51410	Contact tip ø 1.35	24	W0300131	60370	Double pointed spacer	
	W0300137	51411	Contact tip ø 1.6	25	W0300177	60371	Crown spacer	
8		06005	Extended diffusor	26	W0300132	60373	Gouging spacer	
8a	W0300133	52549	Extended electrode		W0300140	04241	Cable, 6m 1/8" - Hand torch	
9	W0300134	51148	Extended tip (for contact cutting max. 50A)		W0300141	04251	Cable, 12m 1/8" - Hand torch	
10	W0300178	51148.13	Extended tip ø 1.35 - 90A (51958 + 51959)		W0300189	04321	Cable, 6m 1/8" - Machine torch	
	W0300179	51148.16	Extended tip ø 1.6 - 120A (51958 + 51959)			04331	Cable, 12m 1/8" - Machine torch	
					W0300117	04260-EWS	Central connector torch side	
					W0300118	04265-EWS	Central connector machine side	
				27	W0300142	60369	Extractor for swirl ring	
				28	W0300119	60368	Wrench for electrode	

Replacement parts suitable for:

EWS®
EX 100 RF

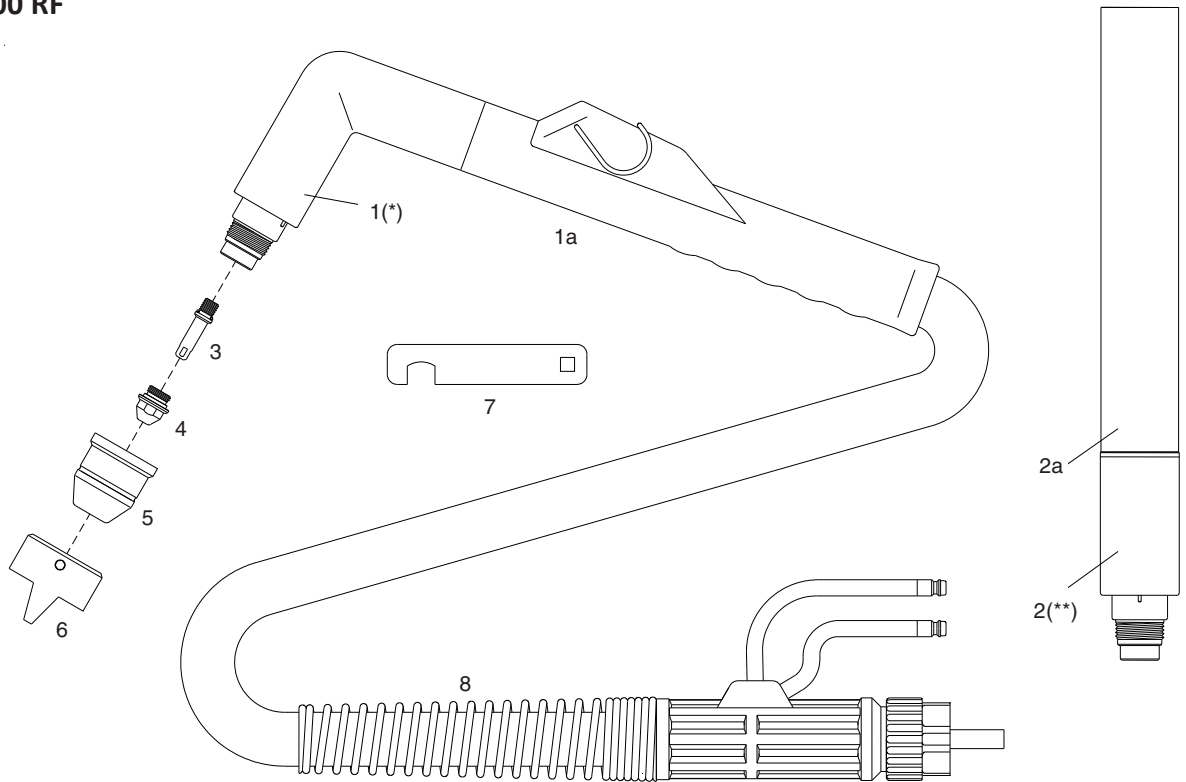

(*) with parts in place and 60354
(**) with parts in place and 80054

No.	Ref.	Code	Description	Pkg.	No.	Ref.	Code	Description	Pkg.
	W0400038	07822	Hand torch 6m central connector	1	4	W0300165	51271/CU	Tip ø 1.3 80A	10
	W0400039	07832	Hand torch 12m central connector	1		W0300161	51272/CU	Tip ø 1.6 120A	10
	W0400040	07842	Machine torch 6m central connector	1		W0300166	51273/CU	Tip ø 1.8 150A	10
	W0400041	07852	Machine torch 12m central connector	1	5	W0300167	80054	Shield cap	10
1	W0300171	07800	Hand torch head (*)	1			60354	Fiberglass shield cap	10
1a	W0300172	04280/C	Handgrip with microswitch	1	6	W0300265	60374	Double pointed spacer	6
2	W0300169	07810	Machine torch head (**)	1	7	W0300250	07800.57	Wrench for tip and electrode	1
2a	W0300168	07215	Machine handle	1	8	W0300173	07882	Cable 6m Hand torch central connector	1
3	W0300160	52751	Electrode with O-Ring	10		W0300247	07887	Cable 12m Hand torch central connector	1
4	W0300163	51269/CU	Tip ø 0.8 30A	10			07892	Cable 6m Machine torch central connector	1
	W0300164	51270/CU	Tip ø 1.0 50A	10			07897	Cable 12m Machine torch central connector	1

Notes
